

DMS-2181T

DeltaMax™ Low-Frequency, Electronically Controlled Sound-Reinforcement Speaker System

- Dual 18-inch manifold enclosure
- EVX-180A woofer for maximum LF output capability with reduced distortion
- 1,200-watt long-term power handling
- New flying system
- 37- to 160-Hz operating range
- Shell dimensions and rigging identical to DMS-1183/64 and DMS-2122/42

Description

The Electro-Voice DMS-2181T subwoofer loudspeaker system is part of the DeltaMax™ series and is intended for high-level sound reinforcement for fixed-installation and touring-sound applications. The DMS-2181T is a double 18-inch loudspeaker system designed to be used with the Electro-Voice Dx34A digital crossover system or any high-quality signal control system.

The DMS-2181T is a vented-box design that utilizes two EVX-180A subwoofers. The EVX-180A subwoofer features a 4-inch voice coil and an extremely high X_{MAX} (maximum linear excursion) for very-high sound-pressure levels at very low frequencies.

The DMS-2181T enclosure is constructed of 18-mm 13-ply birch plywood and is available in a textured black painted version with a standard two-point (two tracks on top, two tracks on bottom) flying system (DMS-2181TPF). The system is a compact trapezoidal shape and includes a unique, protective, vinyl-clad steel grille.

Applications

The DMS-2181T loudspeaker system is an ideal choice for any professional installation or touring application where accurate low-

frequency sound reproduction at high sound-pressure levels is required. The DMS-2181T will produce maximum fidelity with extended bandwidth and reliability for subwoofer applications where high acoustic power is required from 37 Hz to 160 Hz. The DMS-2181T is designed specifically to be used in conjunction with the full-range DMS-1183/64 loudspeaker system and the mid-bass/high-frequency DMS-2122/42 loudspeaker system. The DMS-2181T utilizes a trapezoidal enclosure that has identical dimensions and rigging hardware as the DMS-1183/64 and DMS-2122/42 systems.

Power Handling Test

Electro-Voice components and systems are manufactured to exacting standards to ensure reliability in continuous use in arduous real-life conditions. Besides utilizing industry-standard power tests, extreme in-house power tests which push the performance boundaries of the loudspeakers are also performed for an extra measure of reliability. The DMS-2181T systems are rated per ANSI/EIA RS-426-A Loudspeaker Power Rating, Full Range Test, which uses a shaped-random-noise signal to simulate typical music to test the mechanical and thermal capabilities of the loudspeakers. Specifically, the DMS-2181T passes the

ANSI/EIA RS-426-A power test with the following test parameters:

$P_{E(MAX)}$:	1,200 watts
Test Voltages:	58.7 volts rms
	117.4 volts peak
$R_{SR} (1.15 R_E)$:	2.88 ohms

Crossover, Equalization and Time Delay Controller

The DMS-2181T speaker system and its variants are designed as part of an integrated package that utilize the Electro-Voice Dx34A analog electronic crossover system. Optimal performance of the DMS-2181T speaker system can only be assured when using the above controller. The Dx34A features a 160-Hz crossover frequency utilizing 24-dB-per-octave Linkwitz-Riley filters, and contains time delay and equalization for optional performance of the DMS-2181T.

Electrical Connection and System Wiring

Electrical connections to the DMS-2181T are made on the back of the enclosure via an 8-pin connector. There are two connectors on the input panel to allow paralleling of other DMS-2181T systems. The Neutrik Speakon® NL8MPP is used for both connections. The pin assignments are as follows:

DeltaMax™ DMS-2181T Loudspeaker System

Pin 1+:	LF1(+)
Pin 1-:	LF1(-)
Pin 2+:	LF2(+)
Pin 2-:	LF2(-)
Pin 3+:	No Connection
Pin 3-:	No Connection
Pin 4+:	No Connection
Pin 4-:	No Connection

The wiring diagram of the loudspeaker system is shown in Figure 7. The electrical impedance is shown in Figure 6.

Amplifier Requirements

The DMS-2181T contains two woofers which are separately accessed via the 4-pin input connector. There are two ways the drivers may be wired:

1. Each driver may be connected to its own separate amplifier channel. The recommended power rating is 600-1,200 watts per channel into 8 ohms. The amplifier channels must be identical, having the same voltage gain and power rating.
2. The two drivers may be paralleled to one amplifier channel. The speakers should be paralleled at the amplifier, not at the cabinet. The recommended power rating is 1,200-2,400 watts into 4 ohms.

DMS-2181T speakers may be paralleled only with other DMS-2181T speakers if the amplifier is capable of delivering full power at the lower impedances. The use of amplifiers with lower power ratings is acceptable; however, the full-power capabilities of the DMS speakers will not be realized. The use of amplifiers with significantly higher power ratings will generate maximum dynamic range and fidelity, but care must be utilized for longer duration signals, as mechanical and thermal damage are possible in the system.

Flying The DMS Systems

A manual entitled the *DMS Flying Manual* is available from Electro-Voice, and is included with each flying DMS loudspeaker system. A brief introductory overview is included here. The *DMS Flying Manual* should be consulted for complete structural specifications and detailed information on safely suspending and using the DMS systems.

The DMS-2181TPF is the version of the DMS-2181T loudspeaker system that includes flying hardware. The DMS systems incorporate a unique two-point flying system that permits a wide range of vertical angle adjustment, and offers maximum flexibility in array design for both touring sound and permanent installations. The quick-release, aircraft-rated heavy-duty L-track-type hardware design allows arrays of loudspeakers to be assembled (and disassembled) very quickly, and offers such flexibility in the vertical angling of cabinets that pull-up points are usually unnecessary. Furthermore, all of the flying DMS loudspeaker models include the same rigging hardware, allowing different models to be mixed as necessary throughout an array.

The working-load limit (for an 8:1 safety factor) for each rigging point on the DMS loudspeaker enclosure is 227 kg (500 lb) for a 0° pull angle and 170 kg (375 lb) for a 90° pull angle when used with the New Haven NH32101-2 double-stud fitting, and 113 kg (250 lb) at any angle when used with the New Haven NH8192-2S or Ancra 42546-10 single-stud fittings with locking pins. The working-load limit (for an 8:1 safety factor) for the overall enclosure is 453 kg (1,000 lb). (Consult the *DMS Flying Manual* for specific structural ratings and limitations.) The enclosures may be oriented with the rigging track on the sides of the enclosure, or on the top and bottom, and may be daisy-chained together as long as the safety factor is 8:1 or greater, and local regulations are met. For fire safety and additional structural strength in both flying orientations, top-to-bottom and side-to-side metal straps link the rigging track inside the enclosure. All associated rigging is the responsibility of others.

CAUTION: The DMS loudspeaker system should be suspended overhead only in accordance with the procedures and limitations specified in the *DMS Flying Manual* and manual updates notices.

Field Replacement

The DMS-2181T was designed for expedient field service. Removing the woofer bolts allows the woofer to be easily removed. A woofer failure will require replacement of the entire driver.

The following replacement parts are available from the Mark IV Audio Service in Buchanan, Michigan:

LF: Complete woofer: EV Part No. 818-2389.

Architects' and Engineers' Specifications

The loudspeaker system shall be a low-frequency system with performance controlled by the processors listed in this engineering data sheet. The loudspeaker system shall have two 18-inch low-frequency woofers. Each woofer shall have an 8-ohm, 4-inch-diameter voice coil constructed of aluminum wire, and which shall be capable of handling a 600-watt shaped pink-noise signal with a 6-dB crest factor for eight hours (as per ANSI/EIA RS-426A). The loudspeaker system shall have a sensitivity of 98.5 dB (1 watt at 1 meter).

The loudspeaker system shall have an enclosure constructed of 18-mm, 13-ply birch plywood and shall have a vinyl-clad steel grille.

The loudspeaker dimensions shall be 914 mm (36.00 inches) high, by 572 mm (22.50 inches) wide and 759 mm (29.88 inches) deep and shall weigh 81.2 kg (179 lb). The system shall include a two-point rigging system that will accept New Haven NH32102-2 double-stud ring fittings.

The loudspeaker system shall be the Electro-Voice DMS-2181T.

Uniform Limited Warranty Statement

Electro-Voice products are guaranteed against malfunction due to defects in materials or workmanship for a specified period, as noted in the individual product-line statement(s) below, or in the individual product data sheet or owner's manual, beginning with the date of original purchase. If such malfunction occurs during the specified period, the product will be repaired or replaced (at our option) without charge. The product will be returned to the customer prepaid.

Exclusions and Limitations: The Limited Warranty does not apply to: (a) exterior finish or appearance; (b) certain specific items described in the individual product-line statement(s) below, or in the individual product data sheet or owner's manual; (c) mal-

DeltaMax™ DMS-2181T Loudspeaker System

function resulting from use or operation of the product other than as specified in the product data sheet or owner's manual; (d) malfunction resulting from misuse or abuse of the product; or (e) malfunction occurring at any time after repairs have been made to the product by anyone other than Mark IV Audio Service or any of its authorized service representatives. **Obtaining Warranty Service:** To obtain warranty service, a customer must deliver the product, prepaid, to Mark IV Audio Service or any of its authorized service representatives together with proof of purchase of the product in the form of a bill of sale or receipted invoice. A list of authorized service representatives is available from Mark IV Audio Service at 600 Cecil Street, Buchanan, MI 49107 (800/234/6831 or FAX 616/695/4743). **Incidental**

and Consequential Damages Excluded: Product repair or replacement and return to the customer are the only remedies provided to the customer. Electro-Voice shall not be liable for any incidental or consequential damages including, without limitation, injury to persons or property or loss of use. Some states do not allow the exclusion or limitation of incidental or consequential damages so the above limitation or exclusion may not apply to you. **Other Rights:** This warranty gives you specific legal rights, and you may also have other rights which vary from state to state.

Electro-Voice Speakers and Speaker Systems are guaranteed against malfunction due to defects in materials or workmanship for a period of five (5) years from the date of original purchase. The Limited Warranty does not

apply to burned voice coils or malfunctions such as cone and/or coil damage resulting from improperly designed enclosures. Electro-Voice active electronics associated with the speaker systems are guaranteed for three (3) years from the date of original purchase. Additional details are included in the Uniform Limited Warranty statement.

For warranty repair, service information, or a listing of the repair facilities nearest you, contact the service repair department at: 616/695-6831 or 800/685-2606.

For technical assistance, contact Technical Support at 800/234-6831 or 616/695-6831, M-F, 8:00 a.m. to 5:00 p.m. Eastern Standard time.

Specifications subject to change without notice.

Figure 1—Polar Response

The directional response of the system was measured in an anechoic environment at a distance of 6.1 m (20 feet) using 1/3-octave-filtered pink noise with a full spherical measurement system. The Dx34A digital electronic unit was used to provide the necessary crossover filters, equalization and time delay. The polar response of the loudspeaker system at selected 1/3-octave frequencies is shown. The selected frequencies are representative of the polar response of the system.

Horizontal ———
Vertical - - - - -

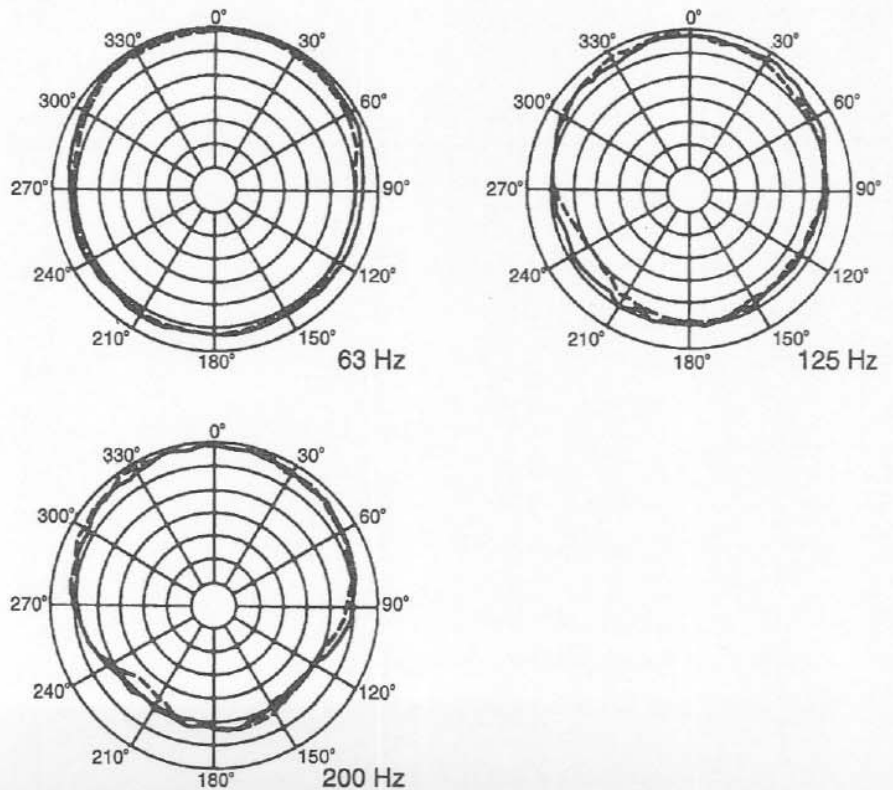
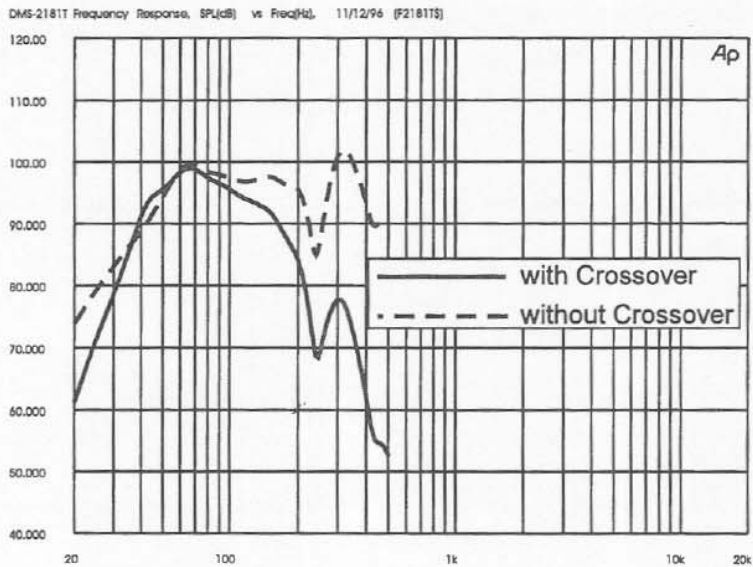
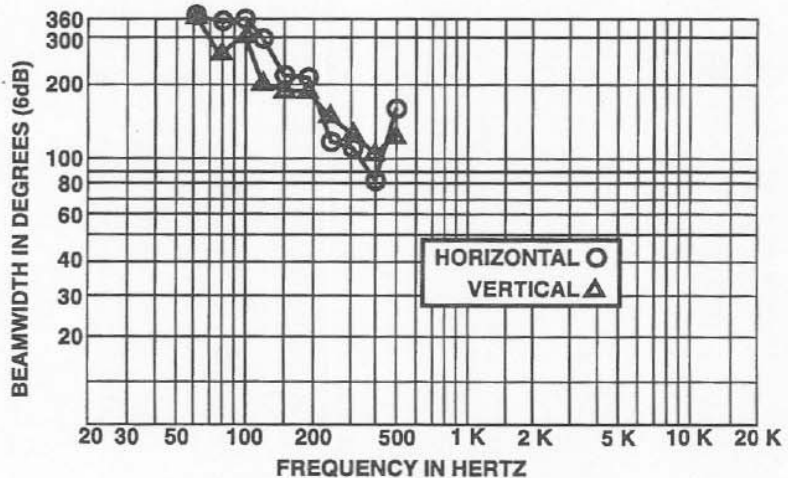

Figure 2—Frequency Response

The frequency response of the system was measured on axis in the farfield in an anechoic environment using a swept sine-wave signal. The Dx34A digital electronic unit was used to provide the necessary crossover filters, equalization and time delay. One watt of power (2.00 volts rms at 60 Hz) was applied to the midband of the low-frequency section. The sound-pressure level was normalized for an equivalent one-meter distance.

Figure 3—Beamwidth

The beamwidth of the system, (i.e., the included horizontal and vertical coverage angles at the 6-dB-down point) was measured with a full spherical measurement system as described in "Polar Response."

Figure 4—Directivity

The directivity index, D_i , and directivity factor, $R_0(Q)$, of the system were measured with a full spherical measurement system as described for the "Polar Response."

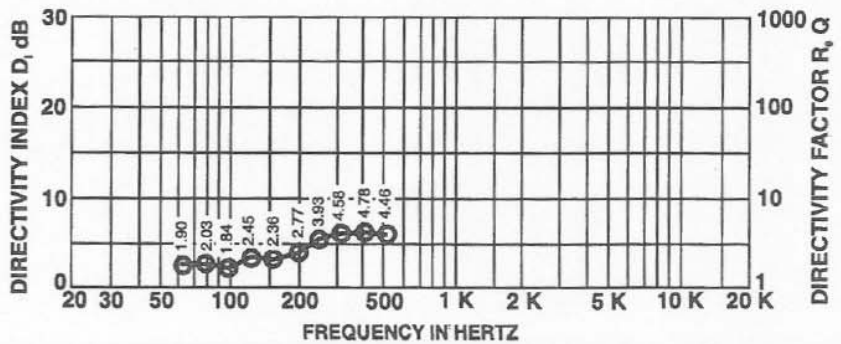

Figure 5—Distortion

Distortion for the system was measured on axis in the farfield in an anechoic environment with an input signal that would result in a sound-pressure level of 115 dB at one meter. The Dx34A digital electronic unit was used to provide the necessary crossover filters, equalization and time delay. A frequency spectrum typical of close-miked rock music was employed. The sound-pressure level was normalized for an equivalent one-meter distance. Plots of second and third harmonic distortion are shown referenced to the fundamental.

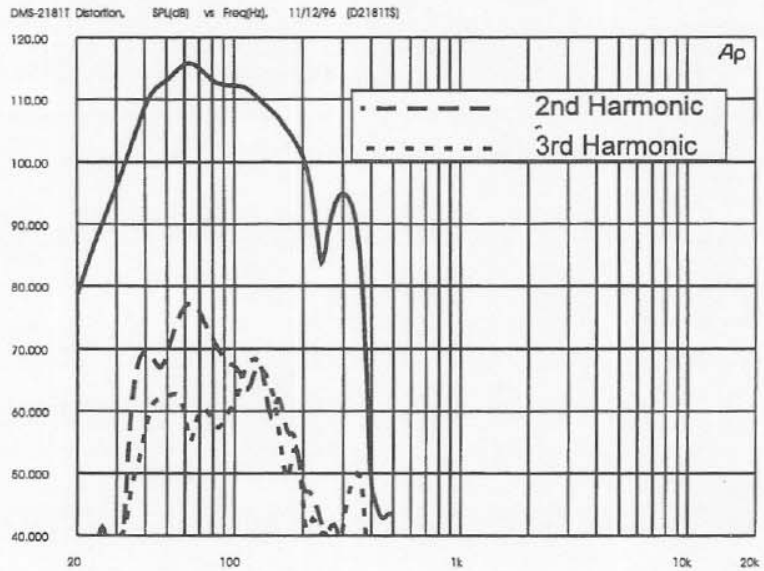

Figure 6—Impedance

The impedance of each frequency band of the system was measured in an anechoic environment.

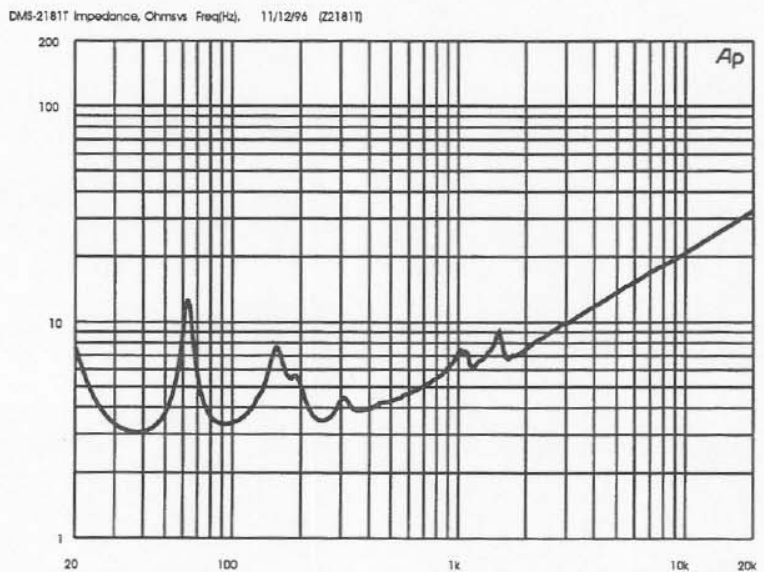
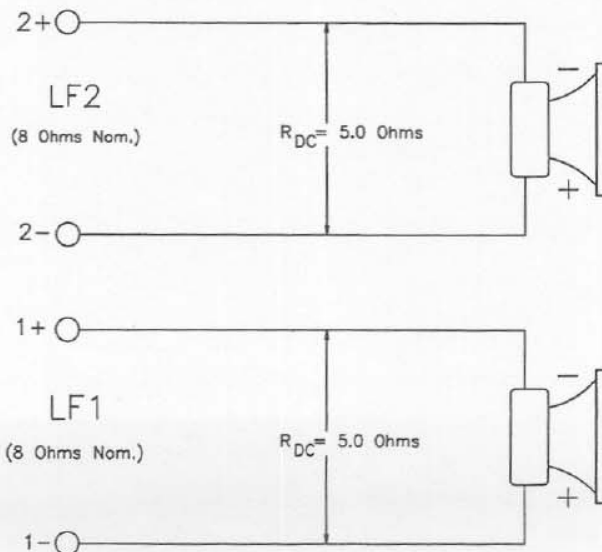

Figure 7—Wiring Diagram

The wiring diagram of each frequency band of the system is shown.



De
Th
lou
ser
rei
tot
is
de
Dx
qu
Th
uti
EV
vo.
mu
pre
Th
18
in:
da
on
Th
an
ste
Af
Th
ide
or

DeltaMax™ DMS-2181T Loudspeaker System

Figure 8—Dimensions

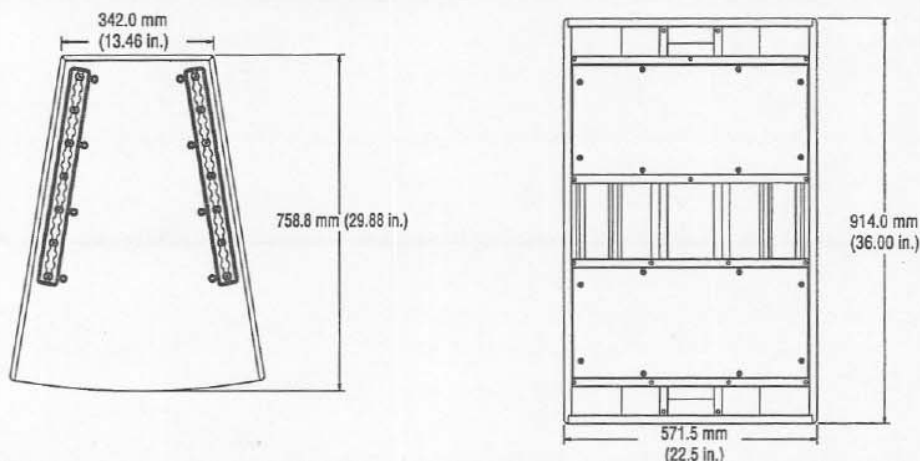

Specifications

Frequency Response (measured in far field, with and without crossover and equalization, calculated to one meter on axis, swept sine wave, one watt into system—2.00 V at 60 Hz, anechoic environment; see Figure 2):

37-200 Hz

Crossover Frequency:

160 Hz

Efficiency:

4.9 %

Maximum Long-Term-Average Power-Handling Capacity (per ANSI EIA RS-426A 1980):

1,200 watts

Maximum Long-Term-Average Midband Acoustic Output:

59 acoustic watts

Sensitivity (SPL at one meter, indicated input power, anechoic environment, average level),

1 watt:

98.5 dB

1,200 watts:

129.5 dB

Beamwidth (angle included by 6-dB-down points on polar responses, indicated one-third-octave bands of pink noise; see Figures 1 and 3),

Horizontal, 80-160 Hz:

260° (+80°, -50°)

Vertical, 80-160 Hz:

225° (+85°, -35°)

Directivity Factor, $R_0(Q)$, 80-160 Hz Average (see Figure 4):

2.17 (+0.19, -0.33)

Directivity Index, D_p , 80-160 Hz Average (see Figure 4):

3.36 dB (+0.37 dB, -0.71 dB)

Distortion (115 dB SPL at one meter, shaped spectrum; see Figure 6),

Second Harmonic,

40 Hz:

1.1 %

80 Hz:

0.8 %

Third Harmonic,

40 Hz:

0.3 %

80 Hz:

0.2 %

Transducer Complement:

Two EVX-180A 18-in. woofers

Impedance (see Figure 6),

Nominal:

4 ohms

Minimum:

3.1 ohms

Input Connections:

Two Neutrik NL8MPR Speakon® connectors paralleled

Recommended Amplifier Power:

1,200-2,400 watts

Enclosure Construction,

Shell:

18 mm, 13-ply birch plywood

Finish:

Black textured paint

Grille:

Vinyl-coated steel with foam

Rigging (DMS-2181TPF only):

Two-point heavy-duty L-track system, accepts New Haven NH32102-2 double-stud fittings, or New Haven NH8192-2S or Ancra 42546-10 single-stud fittings with safety pins

Dimensions,

Height:

914 mm (36.00 in.)

Width (front):

572 mm (22.50 in.)

Width (back):

342 mm (13.46 in.)

Depth:

759 mm (29.88 in.)

Angle:

18° wedge

Net Weight:

81.2 kg (179 lb)

Shipping Weight:

85.3 kg (188 lb)

Electro-Voice®

a MARK IV company

600 Cecil Street, Buchanan, MI 49107